

3HXO SERIES, MULTI ELEMENT FLUOROPOLYMER (PTFE) HEATERS							
WATTS	VOLTS	WIDTH	HOT ZONE	OVERALL LENGTH	MAX. COLD ZONE	MODEL NUMBER	SHIP WGT.
		in./(mm)	in./(mm)	in./(mm)	in./(mm)		Lbs./ (kg)
1500	120	10	6	11	36	3HXO1.5110-06-11-**	15
	240	(255)	(155)	(280)	(915)	3HXO1.5210-06-11-**	(7)
3000	240	10	6	11	36	3HXO3210-06-11-**	20
	480	(255)	(155)	(280)	(915)	3HXO3410-06-11-**	(9.5)
4500	240	10	9.5	17	35	3HXO4.5210-9.5-17-**	21
	480	(255)	(245)	(430)	(890)	3HXO4.5410-9.5-17-**	(9.5)
6000	240	12	10.5	17	35	3HXO6212-10.5-17-**	22
	480	(305)	(270)	(430)	(890)	3HXO6412-10.5-17-**	(10)
9000	240	12	16	23	35	3HXO9212-16-23-**	36
	480	(305)	(405)	(585)	(890)	3HXO9412-16-23-**	(16.5)
12000	240	12	20.5	29	35	3HXO12212-20.5-29-**	42
	480	(305)	(525)	(735)	(890)	3HXO12412-20.5-29-**	(20)
15000	240	12	25	35	31	3HXO15212-25-35-**	48
	480	(305)	(635)	(890)	(790)	3HXO15412-25-35-**	(22)
18000	240	12	29	40	25	3HXO18212-29-40-**	54
	480	(305)	(735)	(1015)	(635)	3HXO18412-29-40-**	(24.5)
24000	240	14	36	47	28	6HXO24214-36-47-**	58
	480	(355)	(915)	(1195)	(710)	6HXO24414-36-47-**	(26.5)
27000	240	14	40	54	30	6HXO27214-40-54-**	64
	480	(355)	(1015)	(1370)	(760)	6HXO27414-40-54-**	(29)

Three phase standard.

Product Features and Benefits:

- ◆ **SUPERIOR CHEMICAL RESISTANCE:** Inert to most aqueous acid, alkaline, anodizing and pickling solutions up to 212°F (100°C).
- ◆ **RUGGED CONSTRUCTION:** Heavy wall fluoropolymer (PTFE) covered stainless steel element reduces permeation and eliminates the need for gas purge systems. Guaranteed 100% pinhole free.
- ◆ **OUTSTANDING PERFORMANCE:** Low watt density design (10 watts/square inch, 1.5w/cm²) for long service life.
- ◆ **CORROSION RESISTANT HEAD:** Vapor tight, flame retardant polypropylene terminal enclosure with 3-foot (.9m) flexible PVC liquid tight conduit.
- ◆ **SAFETY FEATURES:**
 - Grounded internal metal element.
 - Thermal protector built in. Replaceable PT-I fuse standard for solutions up to 190°F (88°C).
 - Non-floating construction.
- ◆ **CERTIFICATIONS:** UL (1.5-18 kW), and CE.
- ◆ **SIZES:** 1,500 watts to 27,000 watts.
- ◆ **VOLTAGES:** 120, 240 or 480 volts. 208, 380, 415, 600 and other voltages available. Three phase standard, single phase available.
- ◆ **OPTIONS AVAILABLE** (consult factory):
 - Replaceable thermal protectors:
 - PT-IM: for solutions from 190°F (88°C) to 220°F (104°C).
 - Resettable thermal protectors:
 - PT-II bi-metal switch: for solutions up to 190°F (88°C).
 - PT-III type-J thermocouple for solutions from 190°F (88°C) to 210°F (99°C).
 - PIII type-J thermocouple for solutions from 210°F (99°C) to 250°F (121°C).
 - Longer vertical lengths (cold zones).
 - Polypropylene guards: recommended for applications up to 180°F (82°C).
 - Fluoropolymer (PTFE) guards: recommended for chromic acid or solutions over 180°F (82°C).
 - Special configurations.
 - Longer wire and conduit lengths.
 - Lower watt densities for highly viscous solutions and technical acids.
 - Temperature and level controls sized to match the heater.
 - Single phase voltage.

DIMENSIONS (up to 18 kW)

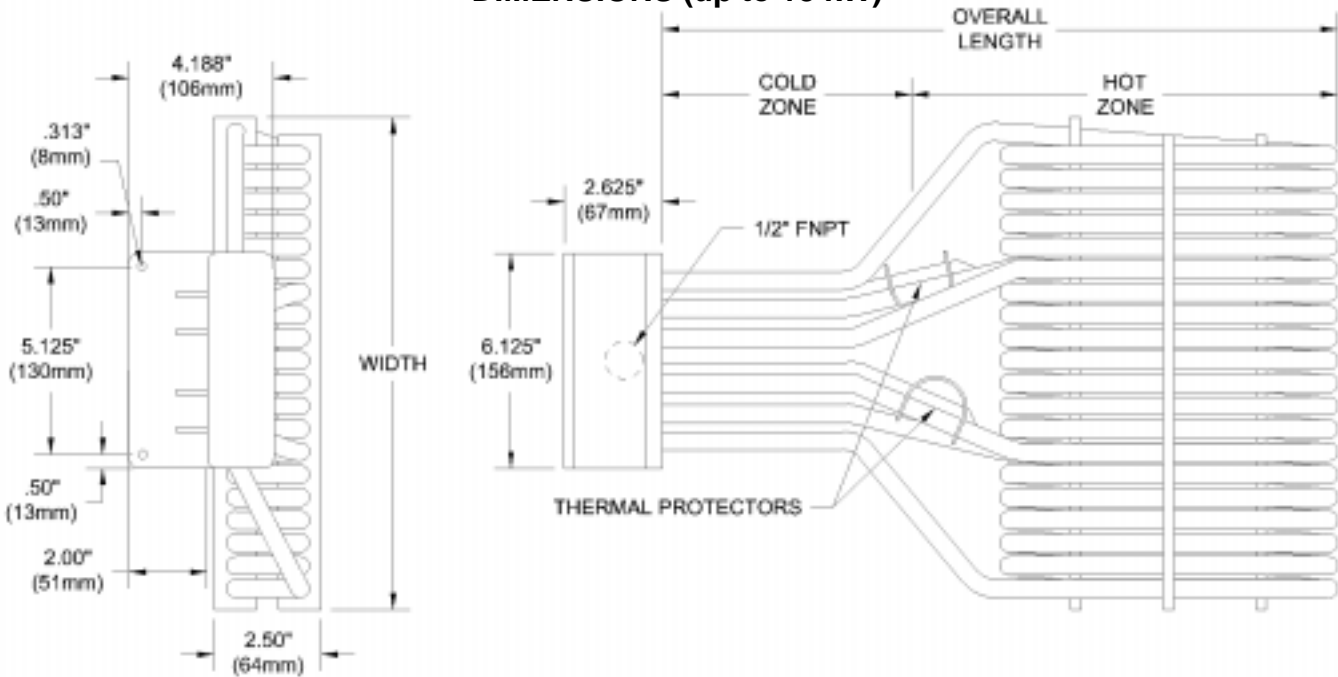

MULTI ELEMENT OVER THE SIDE FLUOROPOLYMER (PTFE) HEATER

Series	Wattage	Voltage	Width	Hot Zone	Overall Length	Options	Type of Fuse	Wire and Conduit Length
	1.5 = 1500 3 = 3000 4.5 = 4500 6 = 6000 9 = 9000 12 = 12000 15 = 15000 18 = 18000 24 = 24000 27 = 27000	1 = 120 2 = 240 4 = 480 -208- = 208 -277- = 277 -380- = 380 -415- = 415 -600- = 600		-06 = 1.5kW -06 = 3kW -9.5 = 4.5kW -10.5 = 6kW -16 = 9kW -20.5 = 12kW -25 = 15kW -29 = 18kW -36 = 24kW -40 = 27kW				no designator = 36" length standard specify variations from standard Ex: -X84 = 84"
		10 = 1.5kW 10 = 3kW 10 = 4.5W 12 = 6kW 12 = 9kW 12 = 12kW 12 = 15kW 12 = 18kW 14 = 24kW 14 = 27kW		-11 = 1.5kW -11 = 3kW -17 = 4.5W -17 = 6kW -23 = 9kW -29 = 12kW -35 = 15kW -40 = 18kW -47 = 24kW -54 = 27kW			<p>Replaceable Fuse</p> <p>-PT-I (std) for solutions up to 190°F -PT-IM for 190° - 220°F solutions</p> <p>Resettable Fuse (additional control components required)</p> <p>-PT-II for solutions up to 190°F -PT-III for 190° - 210°F solutions -PIII for 210° - 250°F solutions</p>	
	3HXO = 3 element PTFE sheathed 6HXO = 6 element PTFE sheathed 3HSO = 3 element 304 stainless steel 6HSO = 6 element 304 stainless steel			specify custom lengths, not to exceed tank length			<p>X = any special configuration not called out in the part number (specify in clear text) C = complete with guard no designator = three phase power (standard) -1 = single phase power</p>	

ORDERING EXAMPLE:

3HXO3210-06-11-PT-I-X50

Multi element fluoropolymer heater, 3000 watts, 240 volt, three phase, 10" wide, 6" hot zone, 11" overall length, PT-I thermal fuse, 50" wire and conduit

O.E.M. HEATERS

www.oemheaters.com

Toll Free: (866) 685-4443

Email: info@oemheaters.com