



Instruction Manual SpotIR Spot Heater

Model 4085

November, 2008



Another quality product from:



7128 Shady Oak Road • Eden Prairie, MN 55344
(952) 949-9009 Fax (952) 949-9559

www.researchinc.com
sales@researchinc.com

Contents

- Introduction..... 1
 - Standard Features..... 1
 - Rapid Response..... 1
 - Continuous Operation..... 1
 - Controllable Energy Output..... 1
- Heater Description 2
 - Heater Module 2
 - Reflector Shield 2
 - Air Cooling 2
 - Power Cord 2
 - Mounting..... 2
- Technical Information..... 3
 - Product Temperatures 3
 - Heat Flux Densities..... 4
 - Heater Module 4
 - Reflector Shield 4
 - Lamps..... 4
 - Air Cooling 4
 - Power Cord 4
 - Mounting..... 4
 - Optional Power Controller..... 4
- Safety 6
 - General..... 6
 - Infrared Radiation 6
 - High Temperatures..... 6
 - Electrical Safety 7
 - Fire Safety..... 7
 - Maintaining Proper Air Flow For Heater Cooling..... 7
- Installation..... 8
 - Unpack and Check for Damage 8
 - Install Cooling Air Source 8

| | |
|--|----|
| Mounting of the Heater | 8 |
| Installation to Model 5420 SCR Power Controller (Optional) | 8 |
| Operating Instructions..... | 9 |
| Maintenance & Troubleshooting | 10 |
| Lamp and Reflector Surface Maintenance..... | 10 |
| Cleaning Internal Reflector Shield Surfaces..... | 10 |
| Model 4085 Emitter Replacement | 11 |
| Dimensions and Specifications | 12 |
| Specification – Model 4085 | 12 |

Introduction

The Model 4085 electric infrared spot heater (Figure 1) is designed for use in any application that requires clean, non-contact heat on a small target or object. Typical applications for this heater include:

- Metal annealing
- Soldering and de-soldering electronic components
- Heating thermoplastic composites
- Localized weld stress relief
- Brazing



Figure 1

Standard Features

Rapid Response

The lamps of these heaters heat up and cool down instantly in response to power control signals. They reach 90 percent of full operating temperature within three seconds of a cold start. The radiant energy dissipates to ten percent five seconds after the power supply is disconnected.

Continuous Operation

The construction of these heaters, combined with air cooling, allow them to withstand continuous high temperature operation.

Controllable Energy Output

The infrared energy emitted from these heaters can be adjusted to match the heating requirements of a variety of applications. PCS/Research Inc. manufactures a complete line of process control instruments and SCR power controllers to control the operation of these heaters.

Heater Description

Heater Module

The Model 4085 incorporates an aluminum elliptical reflector polished to a specular finish. The reflector directs the infrared energy supplied by a tubular quartz infrared lamp to a spot at the ellipse focal point.

Reflector Shield

A reflector shield is supplied with the model 4085 to contain the infrared energy within the desired target area. Three types of reflector shields are available to accommodate a variety of heating applications.

Air Cooling

An air intake fitting is supplied on the Model 4085 for connection of proper cooling air supply.

Power Cord

A power cord with a 120V 15 amp plug is supplied with the Model 4085.

Mounting

Two 1/4-20 UNC tapped holes are provided for proper mounting of the Model 4085.

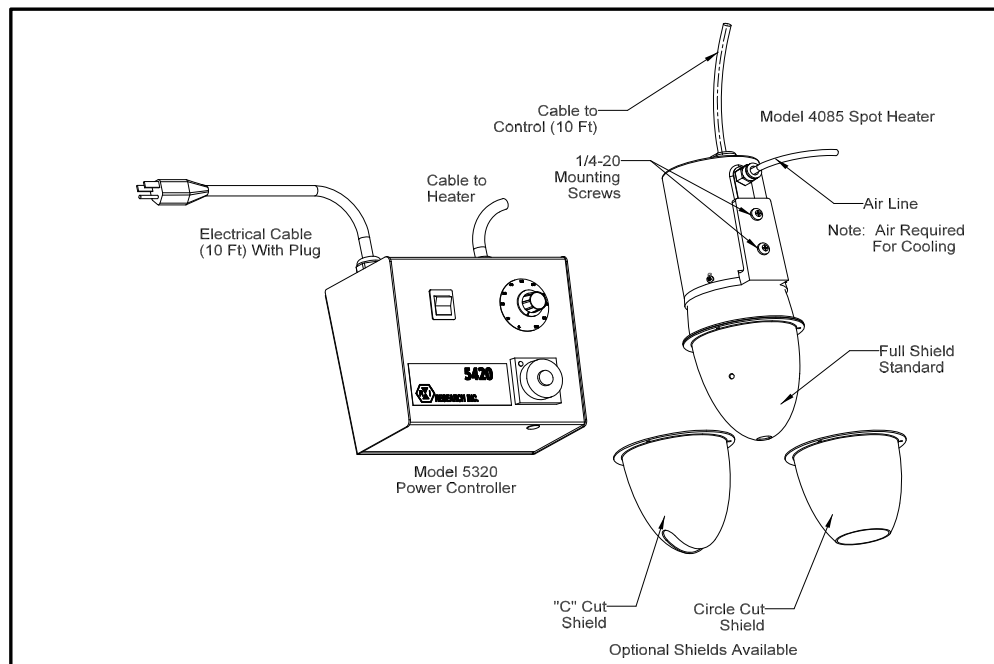

Technical Information

Product Temperatures

Product temperatures to 2000°F (1093°C) can be achieved with the Infrared Spot Heater. Figure 2 illustrates the time to temperature for copper and stainless steel samples heated with a full reflector shield and without a shield. Heating rates are dependent upon the voltage applied to the lamp, the ability of the target surface to absorb radiant energy and the amount of heat loss. For the highest product temperatures and heating rates, a full reflector shield should be used.

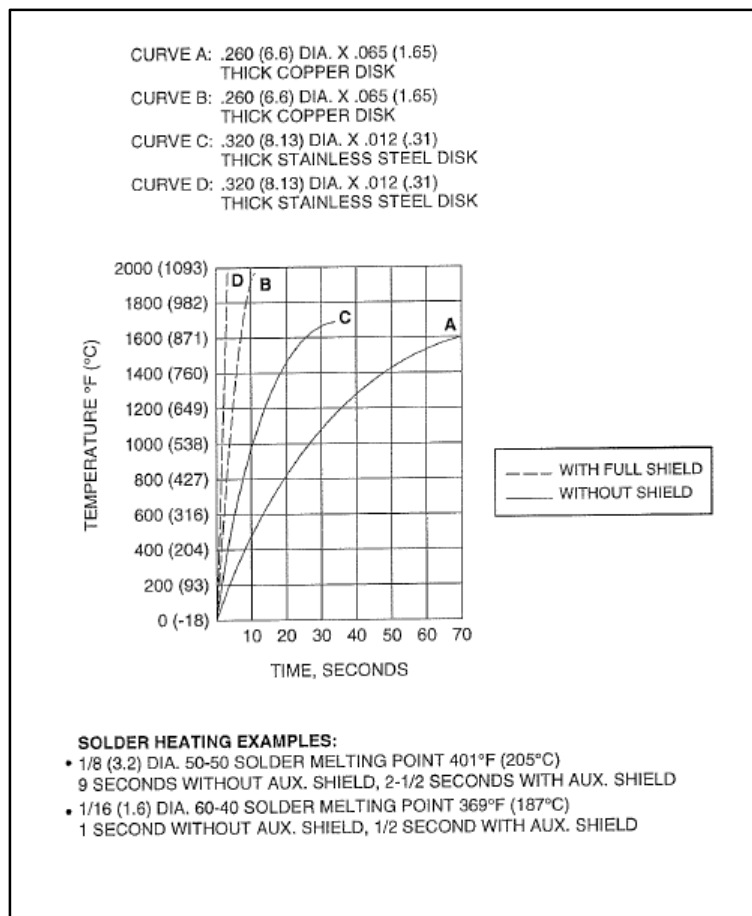

Figure 2 – Heating Rates

Heat Flux Densities

The heat flux generated at the focal point can be as high as 650 watts per square inch (101 watts per square cm) at the center of the focal point with a full shield and 335 watts per square inch (52 watts per square cm) without a shield.

Heater Module

The heater module is 7.22 inches (183 mm) long without a reflector shield. The reflector shield adds 4.5 inches (114 mm) to the overall length of the heater.

Reflector Shield

Three shield types are available: full shield, c-cut shield and circle-cut shield. If a particular shield interferes with objects near the target being heated, it can be cut in the field to fit the application. The reflector shield is attached to the heater module with three screws. The shield type that is required is specified at the time the heater is ordered. Additional shields can also be purchased so that a single heater can be used for a variety of applications.

Lamps

A high intensity, short wave, tubular quartz, infrared lamp is available for the Model 4085. The tungsten emitter in the lamp have an operating temperature of approximately 4000°F (2205°C). Screw-in lamp sockets are spring loaded to provide positive focal positioning. The 750Q/CL lamp (750 watts) products a 0.25 inch (6.4 mm) diameter focal point. Each heater requires one lamp to operate. The 750Q/CL lamp is installed in the standard Model 4085 heater prior to shipment.

Air Cooling

Clean shop air can be provided through the air intake fitting to cool the heater for extended duty applications. The air is directed to the lamp socket and then around the rear side of the reflector to be exhausted around the rim of the reflector. Cooling air should be clean, oil-free and at 100°F (38°C) or less. Air flow rates required to operate the heater, and recommended duty cycles with and without air cooling, are listed in Specifications.

Power Cord

The power cord is 6 feet (1829 mm) long and is equipped with a 120V 15 amp plug.

Mounting

Two ¼-20 UNC by 3/8 inch (9.5 mm) deep tapped holes are provided to mount the heater.

Optional Power Controller

The Model 4085 heater can be ordered with the Model 5420 SCR Power Controller. When so ordered, the heater, power controller, and all necessary interface wiring to connect both units together are shipped. Both units have ¼-turn electrical safety plugs

and approximately 8 feet (2.4 m) of cabling to allow sufficient operating space between the heater and power controller. The 5420 output can be limited from 240 to 120 volts.

Safety

General

The Model 4085 Spot Heater is designed for safe operation. Nevertheless, installation, maintenance and operation of the heater can be dangerous for a careless operator or maintenance person. For your safety and the safety of others, please read the instructions in this INSTRUCTION MANUAL and follow these safety practices which will help to prevent accident or injury.

Infrared Radiation

!CAUTION!

Continuous exposure to high intensity infrared radiation at close proximity could be harmful to eyes or skin. Although ultra violet electromagnetic radiation is not being emitted by infrared lamps, harmful burns could still result if an operator is in close contact with lamps being operated at high intensity.

High Temperatures

Parts of the heater may exceed 500°F (260°C). Contact with the lamps, reflectors, or metal parts near the lamps may cause severe BURNS.

WARNING!

NEVER place hands under the heating elements.

ALWAYS allow heating element to cool at least 5 minutes before touching the lamps or adjacent parts.

Electrical Safety

There is danger of electrical shock when servicing the heater.

!CAUTION!

Observe that all applicable local and national electrical codes are met and a safe electrical ground system is installed before attempting to operate the heater. Refer to the Section 3 for proper installation procedures.

!WARNING!

ALWAYS disconnect the external power lines prior to servicing the heater.

ALWAYS disconnect the power lines AND any optional interlock circuits before installing or changing lamps.

NEVER operate the heater with the heater end covers removed

Fire Safety

1. Obey the same fire-safety rules you observe when you work with hot plates, high intensity infrared heaters, propane or acetylene torches, soldering irons, and other equipment that gets very hot.
2. Remove all solids, liquids, and gases that burn easily from the area around the heater.
3. Know where the nearest fire extinguisher is located and how to use it.
4. Know how to put out fire from all the types of material near the Model 4085 Heater.

Maintaining Proper Air Flow For Heater Cooling

The Model 4085 heater requires airflow of minimum 120 SCFH to operate properly and prolong its life. A fitting is supplied on the heater that accepts flexible tubing which supplies cooling air to the heater.

Failure to supply sufficient cooling to the Model 4085 will cause it to overheat which can lead to premature lamp failure and/or destruction of the heater wiring, body, or reflector.

Installation

Unpack and Check for Damage

Remove the Model 4085 heater from its shipping container and associated packaging. Check the entire unit for any potential damage due to shipping. In the unlikely event damage has occurred, keep all shipping containers and materials and file a damage claim with the shipping company that delivered the heater.

Install Cooling Air Source

Minimum cooling air at 120 SCFH must be supplied to the Model 4085 in order for the heater to operate properly. A 1/14 inch fitting is located on the under side of the heater for plumbing the cooling air to the heater. Attach the hose or tubing to the fitting by removing the ferrule nut from the fitting, slip the nut onto the hose or tubing, insert the end of the tube on the fitting, and tighten the nut to the fitting. It is recommended that flexible tubing be used to simplify mounting of the heater.

Mounting of the Heater

The Model 4085 heater can be mounted to any acceptable bracket, fixture, or other machinery that will support the heater's weight (approximately 4.5 pounds). Two ¼-20 NPT tapped holes with screws are located on the under side of the heater.

Take special care when mounting the heater so that the power cord and air supply tubing are uninhibited from proper operation.

Installation to Model 5420 SCR Power Controller (Optional)

The Model 4085 heater can be ordered with the Model 5420 SCR Power Controller. When so ordered, the heater, power controller, and all necessary interface wiring to connect both units together are shipped. Both units have 120V 15 amps plugs and approximately 10 feet (3 m) of cabling to allow sufficient operating space between the heater and power controller.

It is strongly recommended that all applicable electrical wiring and safe installation codes and practices should be followed in order for the heating system to operate properly and to eliminate unsafe conditions.

Operating Instructions

Note:

Follow all safety procedures and practices called out in Section 2 of this manual.

Operating the model 4085 heater is quite simple and straight-forward once properly installed and mounted within a given application. A SCR (Silicon Controlled Rectifier) power controller is required which supplies electrical power to the heater. Typical examples of this type of power controller include the Model 5420 which can be purchased with your 4085.

The Model 4085 is shipped with a 750 watt infrared lamp installed. At fully applied power (120 volts) the model 4085 emitter generates 750 watts of energy. The emitter will generate 90% output within 3 seconds of applied power.

Note:

Extreme care should be taken to have the heater pointed away from any object that may burn when power is applied to the heater.

The maximum infrared energy generated by the Model 4085 will be concentrated at the heater focal point (approximately 11.25 inches - 286 mm) from the back side of the heater housing (see Figure 3). As shown, this focal point resides at a point inside the Full Shield and C-Cut Shield. Even though the maximum infrared energy resides at this point, a large portion of energy exits the shield at the shield opening. Moving the heater closer to or further from the target (relative to the focal point) will decrease the amount of energy impinging on the target resulting in reduced target temperatures.

Due to the wide variety of materials that can be heated with the Model 4085, experimentation with different power settings to the heater is recommended to determine optimal heater-to-target distance relative to the supplied power.

Figure 3

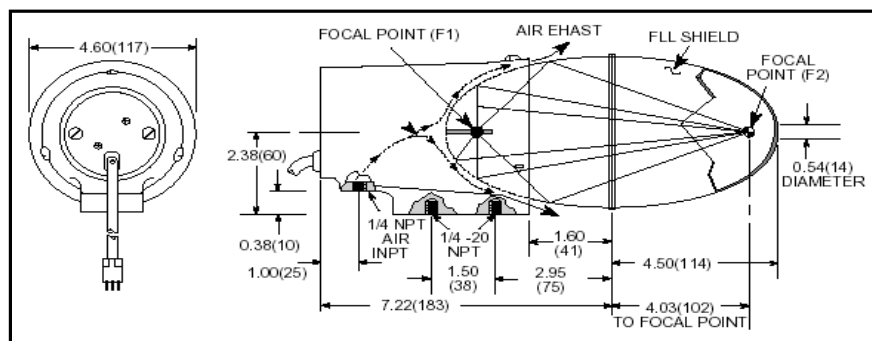

Maintenance & Troubleshooting

The Model 4085 heater requires very little maintenance during its normal lifetime. The life of the heater will be prolonged as long as the proper amount of cooling air (120 SCFH) is supplied and the supply voltage to the heater does not exceed specifications. Periodic inspection and removal of dirt and contaminants will ensure that equipment can be operated safely.

Lamp and Reflector Surface Maintenance

In dirty environments or heating operations the lamps and reflector shields may become contaminated with smoke, dust, fingerprints or other foreign matter. When this occurs it is recommended that they be cleaned. Doing so will extend the life of the lamps and improve the heater's overall performance. Use the following procedure:

!WARNING!

Disconnect the power cable from the power source and allow the heater to cool before continuing.

!CAUTION!

Wear soft, clean, oil-free flannel or plastic gloves when handling quartz lamps. If skin oils come in contact with the quartz tube, the lamp will fail prematurely.

Cleaning Internal Reflector Shield Surfaces

With a soft, clean, oil-free flannel or plastic gloves when handling quartz lamps. If skin oils come in contact with the quartz tube, the lamp will fail prematurely.

1. Remove the reflector shield from the heater casting by loosening the three retaining screws and carefully lifting the shield away from the casting so as to not damage the lamp.
2. Disassemble the reflector shield by removing the nuts and bolts holding both reflector shield halves together.
3. Using a soft, dry cloth or tissue, wipe all visible residue from both shield halves. Household ammonia may be used as a solvent if necessary.
4. Chrome polishing compound can be used with a soft flannel cloth.
5. Reassemble the reflector shield and carefully place it on the heater casting making sure to place the shield half with three screw holes on the casting. Take care to not damage the heater lamp while installing the reflector shield.

6. Align the reflector shield screw holes with the corresponding holes in the heater casting.
7. Reinstall the three retaining screws into the casting and hand tighten them using a Phillips screwdriver.

Model 4085 Emitter Replacement

!WARNING!

Remove all power from the heater BEFORE attempting to replace the Model 4085 emitter.

!CAUTION!

Wear soft, clean, oil-free flannel or plastic gloves when handling halogen, quartz lamps. Oils and contaminants are readily transmitted to the quartz by unprotected hands and can cause premature lamp failure.

Replacement of the Model 4085 emitter is easily performed and takes very little time.

This process is as follows:

1. Remove power to the heater.
2. Remove the two screws holding the heater back plate from the heater housing using a Phillips screwdriver.
3. Carefully remove the back plate/lamp socket assembly from the heater.
4. Unscrew the lamp from the lamp socket by turning counter-clockwise until the lamp is removed from the socket.
5. Screw the new lamp into the socket by turning clockwise until 'hand tight'.
6. Carefully place the lamp/lamp socket/back plate assembly into the heater housing taking care to insert the lamp into the lamp guides mounted within the lamp housing.
7. Rotate the back plate until the notch on the back plate seats into the corresponding key on the heater housing.
8. Place the back plate screws in their original positions and tighten (until snug) using a Phillips screwdriver.

Section 6

Dimensions and Specifications

Specification – Model 4085

| Description | Model 4085 |
|---|------------------|
| Lamp Type | 750Q/CL |
| Total Power Dissipated at 120 Volts, Watts | 750 |
| Current, Amperes | 6.3 |
| Approximate Focal Point Diameter, Inches (mm) | 0.25 (6) |
| Heat Flux Density at Target Surface Without Shield, Watts/Sq in. (W/sq. cm) | 200 (31) |
| Heat Flux Density at Target Surface With Shield, Watts/Sq. in. (W/sq. cm) | 650 (101) |
| Duty Cycle Without Air Cooling, "On" Time, Percent of Duty Cycle | 35 % |
| Duty Cycle Without Air Cooling, Maximum "On" Time Minutes | 6 min. |
| Duty Cycle With Air Cooling, "On" Time, Percent of Duty Cycle | 100% |
| Cooling Air Required | 120 SCFH |
| 4085 Weight | 4.5 lbs. |
| Emitter Life | 500 hours @ 120V |

Ordering information – Model 4085

| Model | Product Description |
|-------------------|--|
| 4085-00-750-00-00 | 4085, 750W Lamp, No controller |
| 4085-00-750-01-00 | 4085, 750W Lamp, Model 5420-120 controller (includes potentiometer) |
| 4085-00-750-02-00 | 4085, 750W Lamp, Model 5420E-120 controller (includes pot, and time |
| 4085-00-750-03-00 | 4085, 750W Lamp Model 5420MA-120 controller (includes 4-20 mA input control) |

Accessories, Spare and Replacement Parts

| Model | Description |
|------------|--|
| 032914-000 | Reflector Shield, Full-cut (interchangeable with internal reflector) |
| 034900-000 | Reflector Shield, Circle-cut |
| 034901-000 | Reflector Shield, C-cut |
| 057550-006 | Halogen Lamp, 750 Watt |
| 057550-005 | Halogen Lamp, 500 Watt |

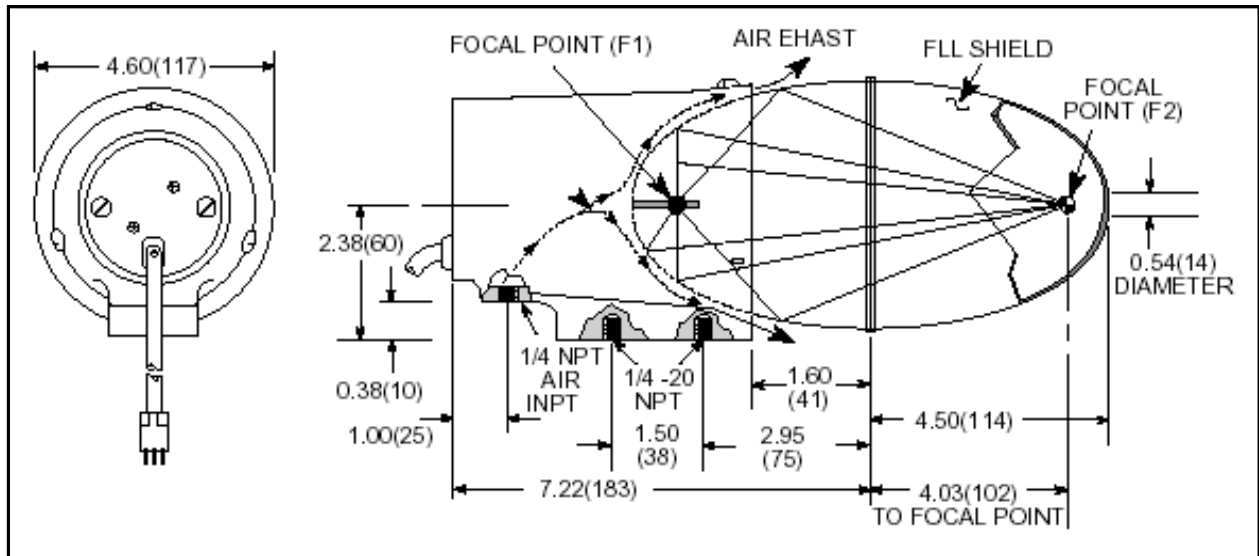

Figure 4 Model 4085 Dimensions

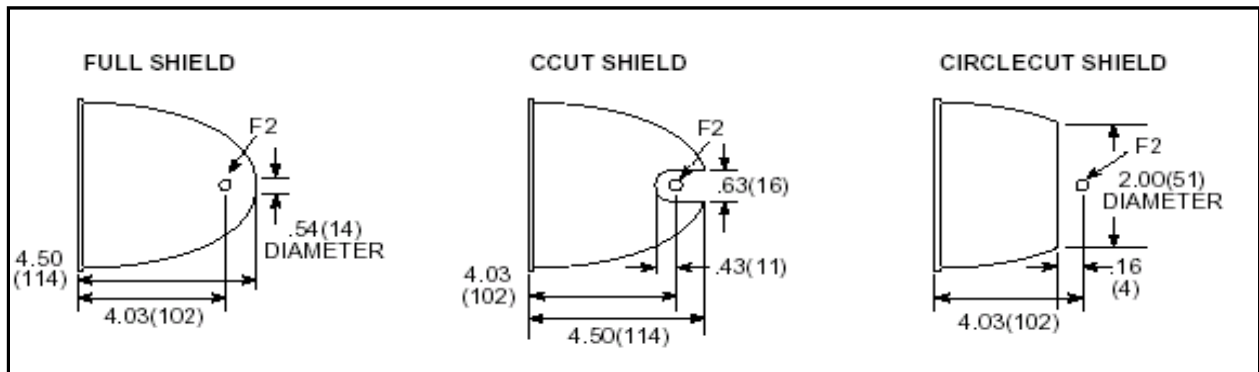

Figure 5 Model 4085 Cone Dimensions